

Our Pride ...

# KML0706

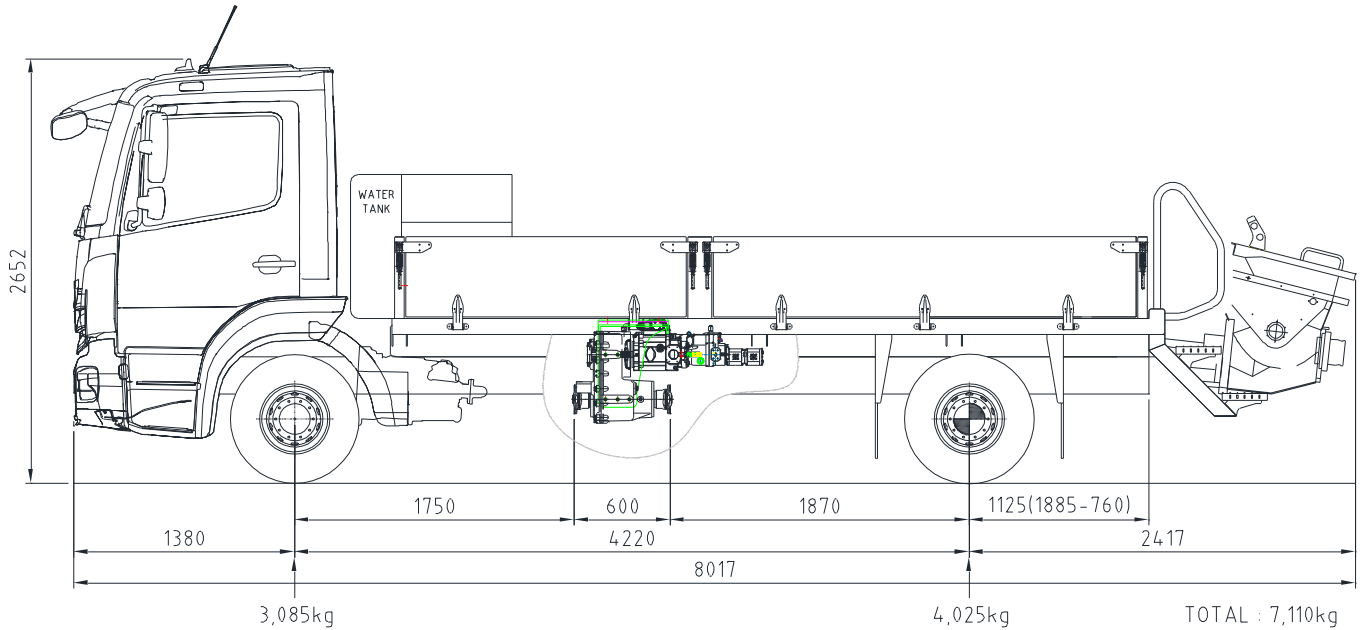

<input checked="" type="checkbox"/> Pump specifications		<input checked="" type="checkbox"/> Performance diagram	
Maximum output	63m <sup>3</sup> /h (82yd <sup>3</sup> /h)		
Concrete pressure	87bar (1,262 psi)		
Stroke per minute	38		
Main cylinder	Ø90/Ø55x1100st (3½"/2"x3'-7")		
Concrete cylinder	Ø180x1100st (7"x3'-7")		
Hopper capacity	0.4 m <sup>3</sup> (14 ft <sup>3</sup> )		
S-tube	Ø180xØ120mm (7"x5")		
Hydraulic pump	KAWASAKI 140S		
Max. aggregate size	40mm (1½")		
TRUCK RPM	1550 rpm		
Vertical distance	125M(410ft)		
Horizontal distance	3,400kg(7,496lb)		

⊙ Truck specifications : Mercedes BENZ\_Atego818 (177PS, EURO6)

⊙ Maximum theoretical values listed.

⊙ Photos and drawings are for illustrative purpose only

⊙ Dimension will vary with different truck makers, models and specifications

⊙ Right to make technical amendments reserved